

# Data Sheet

## Diverter Gates

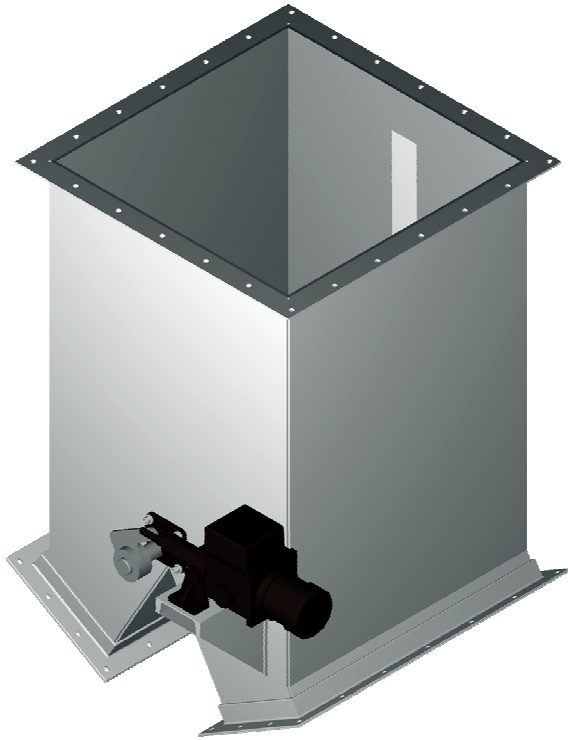

1730 Old Gray Station Road  
Gray, TN 37615  
Ph: 423-282-9900 Fax: 423-282-3118  
sales@picor.biz  
www.picor.biz



PICOR Custom Diverter Gate to customer's specifications

Diverter gates are used extensively in the bulk material processing industry to direct the flow of material to various processing circuits, regulate the amount of flow to various circuits, and to isolate circuits for maintenance. They can be as basic as a single to double diverter with a manual lever to change blade position from one side to the other, or they can be fully automated devices capable of proportioning flow from one or more sources to a large number of destinations.

Diverter gates can be of two designs depending on the characteristics of the material being handled. A simple flat blade diverter is applicable for most materials, is relatively inexpensive, easy to install and maintain. For some material, the non-jamming characteristics and sealing capabilities of the rolling blade diverter make it more suitable.

### Applications

Some typical applications include:

- To direct material from a receiving source, such as a belt, pneumatic, or other type of conveyor, to two or more process lines or storage bunkers individually or proportionately, requires the use of some type of diverter gate.
- If a process consists of multiple parallel process circuits, diverter gates are used to isolate individual circuits for maintenance purposes.
- To maximize the capacity of process plants with multiple parallel process circuits, diverter gates are used to balance the feed to each circuit.

### Actuators

The actuators available for use on diverter gates are:

- Hydraulic
- Pneumatic
- Electric over Hydraulic
- Electric
- Manual

### Construction Materials

Diverter gates can be fabricated from or equipped with a wide range of construction materials depending on the characteristics of the bulk material being handled. Some examples of construction materials for different applications are:

- Carbon Steel with abrasion resistant liners can be used for most applications.
- Polished stainless steel liners can be used to reduce the friction between the bulk material and the gate surface thereby reducing flow problems.
- Stainless steel can be used in all areas in contact with acidic material to prevent corrosion. In some instances it may be necessary to fabricate the entire gate from stainless steel.
- Plastic and rubber seals and liners can be used for a wide range of design features. For example, rolling blade gates can use rubber seals and both types can be equipped with internal or external rubber liners for noise abatement.

### Position Indication

Especially for totally sealed gates, it is important to have a method of determining the position of the gate blade. For gates used to adjust the flow of material, it is necessary to monitor the position of the blade at all times. For some gates it is necessary to determine when they are closed, for others when they are open and for others when they are both open and closed. Some of the devices available to determine the gate blade position are:

- A limit switch can be used to detect whether the gate is closed, open or at any pre-set intermediate position.
- A proximity switch can be used to detect the closed, open or any pre set intermediate position.
- A sensor can be used to continually detect the gate blade position.
- For visual indication, the actuator is usually visible.
- Integral position indication is available from actuator manufacturers to indicate the gate blade position.

### Seals

Seals are available for a wide range of applications including:

- To prevent or reduce escaping dust.
- To isolate the gate from vibration.
- To prevent the transfer of forces between the gate and other structure or equipment.