

Data Sheet

Rack and Pinion Slide Gates

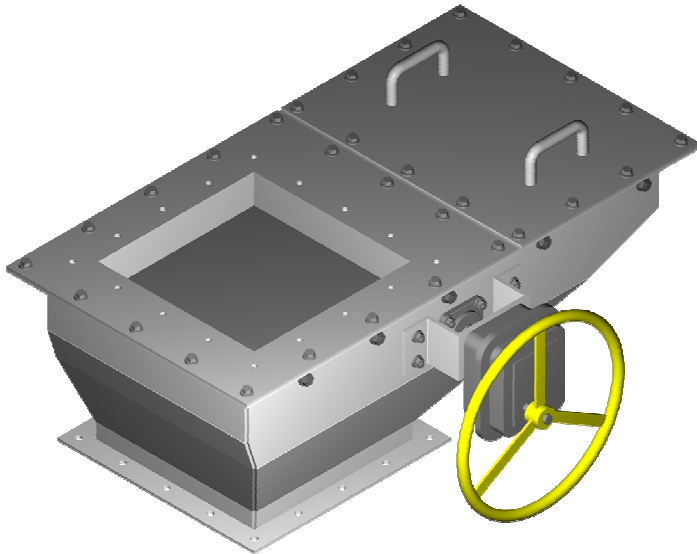

1730 Old Gray Station Road
Gray, TN 37615
Ph: 423-282-9900 Fax: 423-282-3118
sales@picor.biz
www.picor.biz



PICOR Totally Sealed Rack and Pinion Slide Gate

A rack and pinion gate consists of a gate frame, blade, rack(s), pinion gear(s), pinion shaft, shaft bearings, and a manual or powered shaft drive. Some larger manual drives may incorporate v-belts and/or gear boxes for mechanical advantage. Most powered rack and pinion gates will incorporate some type of mechanical advantage between the driver and pinion shaft.

Rack and pinion gates are used generally as maintenance gates ahead of feeders and other equipment. Due to their simple construction, rack and pinion gates can be relied on to operate after months of inactivity. This is especially important in powerhouse and industrial applications.

Due to their limited actuating speed, rack and pinion gates are rarely used to regulate flow into a process or onto a conveyor; however, they are sometimes used to discharge small hoppers that always discharge completely. For example, a rock bin that has a maximum capacity of one truckload may use a rack and pinion gate to shut off flow when a truck is not being loaded.

Rack and pinion gates larger than 60" are seldom economical due to high operating forces and the resulting expensive drive hardware.

Applications

Some typical applications include:

- 18" to 48" rack and pinion gates can be used to load trucks from small coal or rock bins.
- As maintenance gates ahead of coal feeders, pulverizers, crushers, and alternate process systems.
- Most flow control applications not requiring high blade speed.
- Emergency shut off gates to allow maintenance of downstream equipment without unloading the material in storage.

Actuators

The actuators available for use on rack and pinion gates are:

- Hand wheel, chain fall, or ratchet
- Hand wheel, chain fall or ratchet attached to a gearbox
- Electric motor attached to a gearbox
- Hydraulic or air motor attached to a gearbox
- Commercially available rotary actuators

Construction Materials

Rack and pinion gates can be fabricated from or equipped with a wide range of construction materials depending on the characteristics of the bulk material being handled. Some examples of construction materials for different applications are:

- Carbon Steel with abrasion resistant liners to protect the blade supports can be used for most applications.
- Polished stainless steel blade liners can be used to reduce the friction between the bulk material and the gate blade thereby reducing the force required to open the blade.
- Stainless steel can be used in all areas in contact with acidic material to prevent corrosion. In some instances it may be necessary to fabricate the entire gate from stainless steel.
- Blade supports can be commercially available needle bearing rollers, fabricated stainless steel rollers or low friction plastic slide bearings.
- The shafting, racks, and pinion gears can be manufactured from a wide range of alloys to suite the application.

Position Indication

Especially for totally sealed gates, it is important to have a method of determining the position of the gate blade. For some gates it is necessary to determine when they are closed, for others when they are open and for others when they are both open and closed. Some of the devices available to determine the gate blade position are:

- A limit switch can be used to detect the closed, open or any pre set intermediate position.
- A proximity switch can be used to detect the closed, open or any pre set intermediate position.
- A sensor can be used to continually detect the gate blade position.
- For visual indication, a rod attached to the gate blade can be extended outside the gate through a grommet to indicate the blade position.
- Integral position indication is available from actuator manufacturers to indicate the gate blade position.

Seals

Seals are available for a wide range of applications including:

- To prevent or reduce escaping dust.
- To isolate the gate from vibration.
- To prevent the transfer of forces between the gate and other structure or equipment.
- To prevent the escape of water or to direct the water to a collection point.